

Media Information

2011

DIY International

Specialist
magazine for
the DIY market



www.DIYglobal.com

Dähne Verlag

Dähne Verlag GmbH
P.O. Box 10 02 50
76256 Ettlingen (Germany)
Phone +49 / 72 43 / 575-102
Fax +49 / 72 43 / 575-100
advertising@daehne.com
www.daehne.com

Media Information

Editorial and publishing analysis



In brief

DIY International is the specialist magazine for the international do-it-yourself and garden sector. The magazine appears in English and is read by DIY retailers, as well as by suppliers and service providers all over the world. Every issue contains reports on developments in the international DIY trade, current news, previews and reviews of significant trade fairs, detailed country reports complete with statistics and analysis, profiles of manufacturers of DIY and garden products, plus new product announcements. Correspondents on the spot provide their analysis of regional market events. Keynote topics shed light on individual product areas.

Membership

VDZ, SZV

Publisher

Karl-Heinz Dähne

Chief editor

Dr. Joachim Bengelsdorf

Editorial

Rainer Strnad (Managing editor),
Harald Bott

Advertising

Thomas Heinen, Manuel Weber

Volume

Volume 23, 2011

Frequency of publication

4 x (see enclosed schedule)

Publishing house

Dähne Verlag GmbH

Postal address

P.O. Box 10 02 50, 76256 Ettlingen,
Germany

Delivery address

Am Erlengraben 8, 76275 Ettlingen,
Germany

Telephone + 49 (0) 72 43 / 575-102

Fax + 49 (0) 72 43 / 575-100

E-mail advertising@daehne.com

Internet www.DIYglobal.com

Subscription rates

Annual subscription € 50.- incl. p + p

Terms of payment

Net payment due within 20 days
of date of invoice

Terms + Conditions

www.daehne.de/media

Accounts

(D) Deutsche Bank; Kaiserstr. 90
D-76133 Karlsruhe, Nr. 714 600 00
(BLZ 660 700 04)

BIC: DEUTDE33

IBAN: DE68 6607 0004 0071 4600 00

(A) Raiffeisenverband Salzburg
Nr. 160 178 65 (BLZ 35000)

BIC: RVSAAT2S

IBAN: AT84 3500 0000 1601 7865

(CH) Coop Bank Basel
Nr. 481116.290000-8

Clear. Nr. 8440, PC-Kto 40-8888-1

BIC: COOPCHBB

IBAN: CH84 0844 0481 1162 9000 0

Media Information

Circulation | Target groups | Editorial content

Circulation analysis:

Copies per issue represent an average for
July 2009 – June 2010

Number of copies (print and e-magazine)	11 400
Actual circulation	11 298
Remainder and file copies	102
Paid circulation	1 471
Subscriber copies	1 326
Single copies	145
Free copies	9 827

Analysis

2009 = 5 issues

Total size

268 pp = 100.0 %

Editorial

210 pp = 78.4 %

Advertising

58 pp = 21.6 %

of which

Bound-in inserts 0 units = 0.0 % } of

Loose inserts 7 units = 12.1 % } advertising

Analysis of 2009 editorial component

Total	210 pp = 100.0 %
Trade	49 pp = 23.3 %
Industry	0 pp = 0.0 %
Garden	0 pp = 0.0 %
News	25 pp = 11.9 %
Statistics	1 pp = 0.5 %
Trade fairs/congresses	18 pp = 8.6 %
New products	30 pp = 14.3 %
Country reports	32 pp = 15.2 %
Others	55 pp = 26.2 %

Circulation by target groups

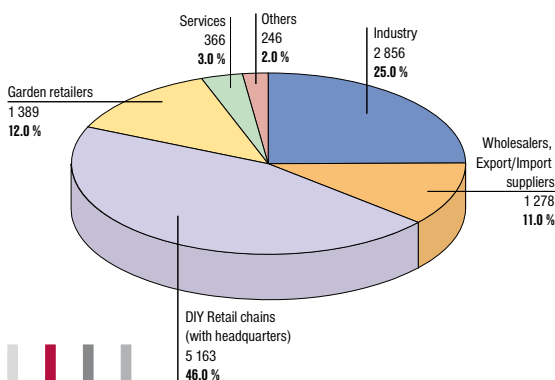

Geographical analysis of circulation

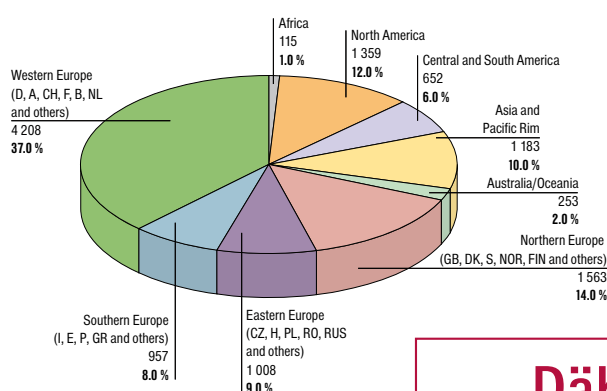

Advertisement formats and rates

Format

210 mm width, 297 mm depth, DIN A 4

Type area

187 mm width, 270 mm depth

Columns

4 columns, 43 mm wide

Printing and binding processes

Offset printing and stapled binding

Copy

Copy up to 70 lines per cm/300dpi.
However, please pay careful attention to the technical instructions.

Frequency of publication:

Four times a year

Publication dates

Refer to schedule

Advertising deadlines

Refer to schedule

Format	Number of columns	Width x Depth in mm	Basic price black/white €	2 colours €	3 colours €	4 colours €
1 / 1 page	4 columns	187 x 270	2 270.-	2 785.-	3 300.-	3 815.-
1 / 2 page	4 columns 2 columns	187 x 133 horizontal 91 x 270 vertical	1 160.-	1 630.-	2 100.-	2 570.-
1 / 3 page	4 columns	187 x 87	790.-	1 160.-	1 530.-	1 900.-
1 / 4 page	4 columns 2 columns 1 columns	187 x 64 horizontal 91 x 133 vertical 43 x 270	600.-	860.-	1 120.-	1 380.-
1 / 8 page	4 columns 2 columns 1 columns	187 x 30 horizontal 91 x 64 vertical 43 x 133	300.-	510.-	720.-	930.-
1 / 16 page	2 columns 1 columns	91 x 30 horizontal 43 x 64 vertical	160.-	320.-	480.-	640.-
back cover	4 columns	187 x 270	2 840.-	3 355.-	3 870.-	4 385.-
inside front cover	4 columns	187 x 270	2 630.-	3 145.-	3 660.-	4 175.-
inside back cover	4 columns	187 x 270	2 430.-	2 945.-	3 460.-	3 975.-

Rate per single-column millimetre: € 2.70 in advertising section, € 4.70 in editorial section

Surcharges and other prices

Surcharges per standard colour (Euro scale)/special colour (basic 4c)

≥ 1/1 page	€ 515.-	1/4 page	€ 260.-
1/2 page	€ 470.-	1/8 page	€ 210.-
1/3 page	€ 370.-	≤ 1/16 page	€ 160.-

HKS, pantone and metallic colour extra surcharge € 260.-

Special formats/positions

2/1 page	on request
Front cover flap	see extra information
Guaranteed positions	€ 230.-
Print over gutter margin	€ 115.-
Bleed additional 3 mm	10 % of basic rates

Small advertisement rates

Situations vacant per mm	€ 2.70
Private situations wanted per mm	€ 2.16
Charge for box number	€ 6.00

All employment ads will also appear for one month free of charge on www.DIYglobal.com

Rubric DIY@Internet

Standard entry (company, internet address)	€ 20.-
Maxi entry (logo, company, internet address)	€ 70.-
Premium entry (logo, company, internet address, random rotating banner at www.DIYglobal.com)	€ 115.-
Minimum period of 4 issues	

Discounts

Valid for one year
from publication
date of first insertion

Frequency rates

2 x 2 %	2 pages 5 %
4 x 5 %	4 pages 10 %
8 x 10 %	8 pages 15 %

Volume rates

Combination discounts of 10-15 % on additional insertion of same-format advertisements in *diy* Fachmagazin or HOLZFORUM parallel issue.
No discount on loose or bound inserts.

Bound inserts

4-sided	6-sided	8-sided
€ 4 540.-	€ 6 360.-	€ 7 950.-

Loose inserts

Maximum size 205 x 292 mm	
Up to 25 g %	€ 238.-
Up to 50 g %	€ 360.-

Adhesive postcard

% € 150.-

Delivery address for inserts

Kraft Druck GmbH
Betr.: DIY International No. ...
Industriestraße 5
76275 Ettlingen (Oberweier), Germany

A sample copy must be supplied in advance to Dähne Verlag GmbH, Advertising dept, P.O. Box 10 02 50, 76256 Ettlingen, Germany

Media Information

Schedule and editorial topics

Issue	Schedule	Keynote topics
1/ 2011	Publication date 27.01.2011 Advertising deadline 10.01.2011 Copy deadline 11.01.2011 Editorial deadline 20.12.2010	Themed issue: Opening up new markets Regional report: North Europe Fair reports: Totally DIY/Totally Tools/Totally Secure, Birmingham, Great Britain 6 – 8 Feb. Ferroforma/Bricoforma, Bilbao, Spain, 23 – 26 March Asia-Pacific Sourcing, Cologne, Germany 9 – 11 March
2/ 2011	Publication date 27.04.2011 Advertising deadline 30.03.2011 Copy deadline 06.04.2011 Editorial deadline 21.03.2011	Regional report: Eastern Europe Fair report: National Hardware Show, Las Vegas, USA, 10 – 12 May
DIY- Buyers' Guide 2011	Publication date 22.06.2011 Advertising deadline 01.05.2011 Copy deadline 05.05.2011	The DIY Buyers' Guide is an invaluable aid for shaping the product offer in DIY and building stores and in specialist outlets with DIY and garden departments. Please ask for our special media rates.
3/ 2011	Publication date 28.07.2011 Advertising deadline 07.07.2011 Copy deadline 11.07.2011 Editorial deadline 20.06.2011	Themed issue: Sales promotion, secondary placement, clearance sales campaigns Regional report: Australia and New Zealand Fair reports: Spoga+Gafa, Cologne, Germany, 4 – 6 Sept. Glee, Birmingham, Great Britain, Sept. DIY + Homing, Kortrijk, Netherlands Sept. CIHS, Peking, China, Sept. Taiwan Hardware Show, Taipei, Taiwan, Sept. Eurobrico, Valencia, Spain, Nov.
4/ 2011	Publication date 27.10.2011 Advertising deadline 06.10.2011 Copy deadline 10.10.2011 Editorial deadline 19.09.2011	Regional report: Benelux Fair report: Domotex, Hannover, Germany, Jan. 2012
DIY + Garden Show Guide 2012	Publication date Nov./Dec. 2011 Advertising deadline 14.09.2011 Copy deadline 16.09.2011	This compilation of the world's major DIY, garden and building materials trade fairs is a comprehensive planning aid for the industry's decision-makers. Consequently the DIY and Garden Show Guide is the ideal advertising medium for trade fair organisers and exhibitors. Please ask for our special media rates.
1/ 2012	Publication date 26.01.2012 Advertising deadline 09.01.2012 Copy deadline 10.01.2012 Editorial deadline 18.12.2011	Themed issue: Quality assurance Regional report: Germany, Austria, Switzerland Fair report: International Hardware Show, Cologne, Germany, 4-7 March 2012

Media Information

Special forms of advertising: Pocket



The pocket is a special insert in a handy DIN A6 format (147 mm high and 104 mm wide), which is glued into an issue of DIY International. The editorial team produces the contents in collaboration with the client.

The layout is the "DIY International Layout", which gives the product a high degree of credibility. Depending on the issue, this presentation option is offered exclusively to just one company.

Pocket standard (20 pages in total)

1 title page, 18 pages of content, 1 full-page advert 4c € 7 425.-

Pocket XL (28 pages in total)

1 title page, 25 pages of content, 2 full-page adverts 4c € 9 547.-

Pocket XXL (36 pages in total)

1 title page, 32 pages of content, 3 full-page adverts 4c € 11 668.-

The pocket is glued onto an editorial "carrier page", which also features content on the client's company.

Additional services: Publication on www.DIYglobal.com, 100 specimen copies, higher circulation for an additional charge.



Media Information

Product presentation

Product presentations are the special form of advertising for everyone who has more to say.

Present your products in a editorial style.

¼ page 4c

1 photo, 30-character heading and 600-700 characters of text (incl. spaces) € 325.-

A maximum of 4 product presentations can be included per issue. The same product can be presented no more than once a year, unless included within the special "New Products of the Year" section. The editorial team reserve the right to cut texts if necessary and to edit them in conformity with the magazine's language guidelines.



Media Information

Special advertising formats

Got an idea for an unusual advertising format? Want your ad to be even more striking?

Then talk to us. We work with you to realise advertising formats that attract greater attention. No matter whether they're island advertisements, L-adverts, round adverts, adverts with punched-out parts, fold-out pages, magazine banderoles – there's a host of possibilities!

We'll turn your ideas into reality, to make your advertising even more noticeable.

Sales down at Roma

For the first quarter the Canadian Home Store has experienced a sales decline of 7.2 per cent to US\$ 846 million. A decline of 8.1 per cent is reported in the Netherlands (US\$ 614.2 million) and 12.2 per cent in the UK (US\$ 1,268 million). The group's sales in the quarter are down 10.1 per cent to US\$ 1,515 million.

Downward slide

Sales in the Netherlands fell 12.2 per cent to US\$ 614.2 million compared to the same period last year. In the UK sales fell 12.2 per cent to US\$ 1,268 million. In Germany sales fell 8.1 per cent to US\$ 632 million.

In the fast lane

The DIY retailer is content with another double-digit increase in sales. The group's sales in the quarter are up 12.2 per cent to US\$ 1,515 million. In the Netherlands sales are up 12.2 per cent to US\$ 614.2 million. In the UK sales are up 12.2 per cent to US\$ 1,268 million. In Germany sales are up 12.2 per cent to US\$ 632 million.

Double-digit rates of decline

In the first quarter of 2008, the Canadian Home Store experienced a sales decline of 7.2 per cent to US\$ 846 million. In the Netherlands sales fell 12.2 per cent to US\$ 614.2 million. In the UK sales fell 12.2 per cent to US\$ 1,268 million.

Canasud growth of DIY business

The Canadian Home Store has experienced a sales decline of 7.2 per cent to US\$ 846 million. In the Netherlands sales fell 12.2 per cent to US\$ 614.2 million. In the UK sales fell 12.2 per cent to US\$ 1,268 million.

Furniture from DIY stores

The Canadian Home Store has experienced a sales decline of 7.2 per cent to US\$ 846 million. In the Netherlands sales fell 12.2 per cent to US\$ 614.2 million. In the UK sales fell 12.2 per cent to US\$ 1,268 million.



How to corner the garden market

Example: L-advert across spine

Media Information

Cover flap advertisements

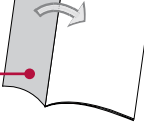
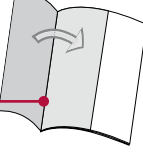
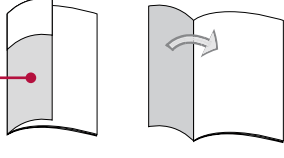
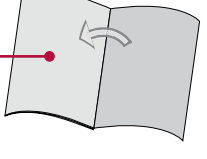
Cover flap advertisements are placed on additional fold-out pages on the cover:

<p>Cover 1 ½ page inside left cover flap (1/2 cover)</p>	€ 4 590.-		Cover 1
<p>Cover 2 1/1 page (over gutter margin) inside left cover flap (1/2 cover) and left half side cover</p>	€ 5 896.-		Cover 2
<p>Cover Special 2 columns/187 mm high below the magazine logo outside the left cover flap (1/2 cover) + ½ page on the same cover flap inside</p>	€ 6 590.-		Cover Special
<p>Cover XXL The complete cover flaps to the right Inside is a 2/1 page ad over gutter margin</p>	€ 10 404.-		Cover XXL
<p>Cover Gate 2 cover flaps (1/2 cover to the left and ½ cover to the right) with an 2/1 page ad over both gutter margins</p>	€ 10 190.-		Cover Gate

Media Information

Procedures and specifications for the supply of advertising material

All data must be supplied as print quality PDF or directly processable EPS.

Please also ensure that

- all colours are created as CMYK or desired special colours;
- all directly processable images and graphics are encapsulated;
- all type fonts used are encapsulated;
- images are stored exclusively in bitmap, grey-scale or CMYK mode.
By no means may "indexed" colours, RGB or other modes be used.
Image format either TIFF or EPS.
- images are not stored as DCS images, since we process uncompartmented data. We must be informed if any DCS images are included in the material (to avoid any possibility of accidentally poor resolution). If you do include any DCS images, we will convert them and invoice you as appropriate.
- you provide a reliable printout of the data, since we have no other way of checking the accuracy of the proof.

We can not guarantee correct reproduction unless we receive your printout before the copy closing date. This is particularly important for colour reproduction.

Data transfer by E-mail

Such files should not exceed 20 MB in size. E-mail: copy@daehne.com

Data file upload via FTP

Send us an E-mail to copy@daehne.com and ask for your personal log-in information.

Please utilise the following procedure for naming your file

Abbreviation* of publication title + issue number + name of advertiser
e.g.: DIN2-10Miller.pdf

*Abbreviations:

diy = diy Fachmagazin; DIN = DIY International; HF = HOLZFORUM;
pet = pet Fachmagazin; PWW = PET worldwide; AQ = Aquaristik;
Car = Caridina; GT = Gartenteich

Data by data carrier

Use can be made of any current data carrier.

Programs suitable for direct processing

QuarkXPress 4.11, 5.01, 6.5, 7.3, 8.0 (Mac + PC);
InDesign CS2, CS3, CS4 (Mac + PC);
Illustrator CS2, CS3, CS4 (Mac + PC);
PhotoShop 7.0, CS2, CS3, CS4 (Mac + PC);
Freehand 10, MX (Mac); CorelDraw 12 (Mac + PC);
Mac Office X 2004 (Mac); FrameMaker 6.0 (PC)

You'll find information on the technical specifications for loose inserts, bound inserts, tip-on cards and product samples on the internet at www.daehne.de/media

Your Dähne advertisement team



Managing director
Marc Dähne
m.daehne@daehne.de
Phone +49/7243/575-102



Advertising manager
Thomas Heinen
t.heinen@daehne.de
Phone +49/7243/575-110



Advertisement sales
diy Fachmagazin
DIY International, HOLZFORUM
Manuel Weber
m.weber@daehne.de
Phone +49/7243/575-106



Advertisement sales
pet Fachmagazin
PET worldwide
Patricia Bader
p.bader@daehne.de
Phone +49/7243/575-104



Advertisement sales
Aquaristik, Caridina,
Gartenteich
Angelika Müller
a.mueller@daehne.de
Phone +49/7243/575-105

The advertising agent for your country:



Advertisement administration
Christa Mantel
c.mantel@daehne.de
Phone +49/7243/575-102



Advertisement administration
Gabriele Santai
g.santai@daehne.de
Phone +49/7243/575-103



Benelux/Scandinavia
Lothar Wittich
Westfehling Development GmbH
Phone +49/54 39/80 90 00
Fax +49/54 39/8 09 00 99
l.wittich@daehne.com



France/Italy
Gloria Oddone-Ebken
Westfehling Development GmbH
Phone +49/541/6 00 52 08
Fax +49/541/6 00 52 09
g.oddone-ebken@daehne.com



**USA/Canada/UK/
Ireland/Israel**
Les Rose
Elarco International Ltd.
USA/Canada +1/630/618-225
UK/Ireland +44/121/288-2161
Israel +972/545/746-990
l.rose@daehne.com
Skype: elarco

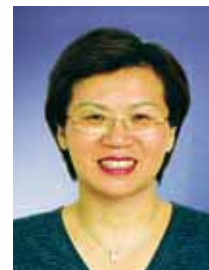

Taiwan
Joy Wang
Infotrade Media Co., Ltd.
No. 508, Sec. 3,
Wen Hsin Rd., Situn Dist.
Taichung 40753, Taiwan
Phone +886/4/23 13 21 89 203
Fax +886/4/23 13 32 39
service@trade-eye.com